

# TTRF2 THE SMART GATEWAY MODULE

For non-powered  
asset tracking



1212 Broadway Plaza  
Suite 2100  
Walnut Creek, CA 94596  
United States Of America  
+1 866 355 5552  
sales@bransys.com  
www.eztotrack.com

**Why TTRF2?** Long lasting IoT device with extremely low power consumption, adaptive power management, supporting a multi-protocol platform. Supports modern high-tech protocols such as Bluetooth 5.0, Bluetooth Mesh, Zigbee, and various proprietary and standardized 2.4GHz stacks.

## FEATURES

- Primary non-rechargeable and rechargeable lithium-ion battery
- Up to 10 years battery life
- Latest GPS/GLONASS/BeiDou/Galileo positioning technology
- LTE Cat M1/ LTE NB / EGPRS
- Long Range Bluetooth 5.0 / ZigBee / 2.4 Ghz / CyFi communication with external sensors
- Real Time tracking
- Supports TCP/IP and UDP protocols
- Customized firmware configuration via USB and remote update with FOTA
- Motion and temperature sensors
- Temperature controlled range of peak power consumption

## INTERFACE

- Long Range Bluetooth 5.0 / ZigBee / 2.4 GHz connection
- CyFi™ Low-Power RF 2.4 GHz
- 4x digital input, 2x analog input & 2x Open-Collector Outputs
- 1-wire Protocol
- Supports OBD protocols: J1708/1587, J1939 CAN Bus, J1979 CAN Bus, ISO 15765
- USB port & Serial port RS485
- 3.3V DC Output Pin
- Power supply: (+8V to +30V) DC
- Internal GSM and GPS antennas
- 3-axis Accelerometer
- 4 Status LEDs
- Temperature range: -40°C to +85°C



## CELLULAR MODULE CERTIFICATIONS

- Certified to FCC, IC, MIC, KCC, and NCC radio regulations
- Certification: FCC/PTCRB LTE Modem

# ENVIROMENTAL PROTECTION

The module is mounted on the outside frame of the container, the trailer, or to the trailer chassis. The enclosure is designed with resilience, robustness, and IP67 compliance in mind, and as such is comprised of a specific combination of microfiber and plastic materials. HALT testing has ensured a resistance to **humidity**, **mechanical shock**, and **vibration**.

The enclosure's thermal design ensures that the processor's **operating temperature** remains within the optimal range while also shielding the unit from harmful UV rays, as a result avoiding overheating and securing reliable operation regardless of the operating environment.

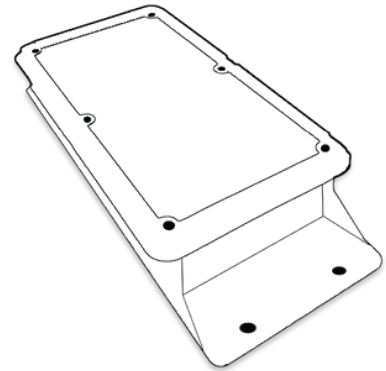

## SENSORS - OPTIONAL

- TracBAT Hubodometer® - Stemco
- AERIS SmartSense® Automatic Tire Inflation System - Stemco
- AirBAT RF® Tire Pressure Monitoring System - Stemco
- Cargo Temperature Sensor
- Fuel Level Sensor
- Door Sensor
- Cargo Load Sensor
- Proximity Sensor

## ELECTRICAL SPECIFICATIONS

### Power Consumption

- <15uAh in sleep mode
- <200 mAh in normal active mode

### 2 Types of Batteries

- Primary non-rechargeable battery: with capacity up to 48Ah
- Rechargeable battery: with capacity up to 6.6Ah
- Life span up to 10 years